

| REV. | CHANGE               | DATE       | DESIGNED | APPROVED |
|------|----------------------|------------|----------|----------|
| D    | ITEM NUMBERS CHANGED | 23.08.2021 | RIL      | VPA      |

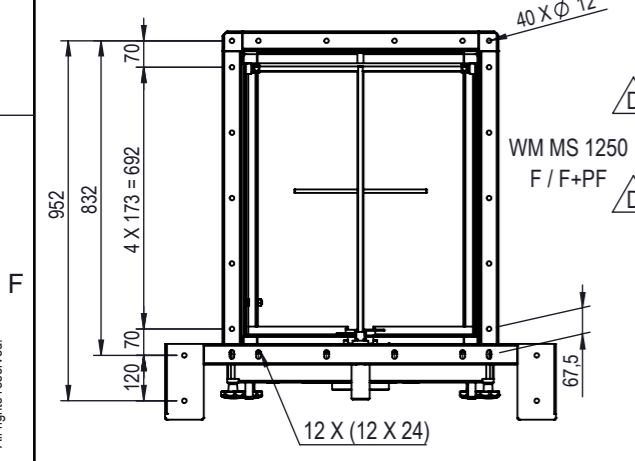
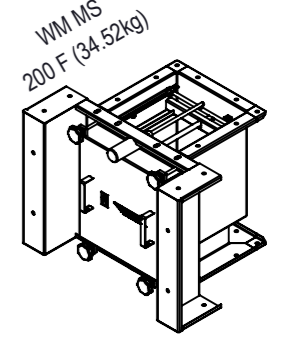
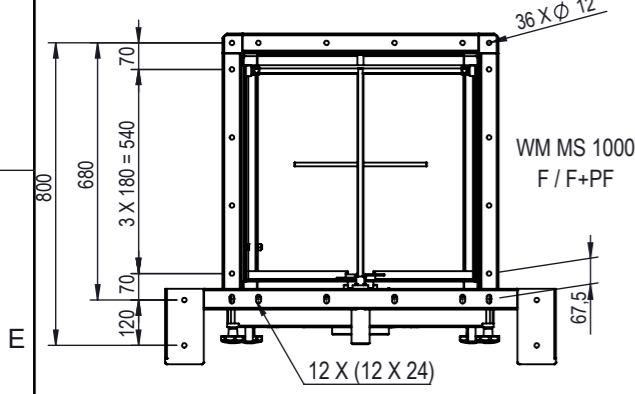
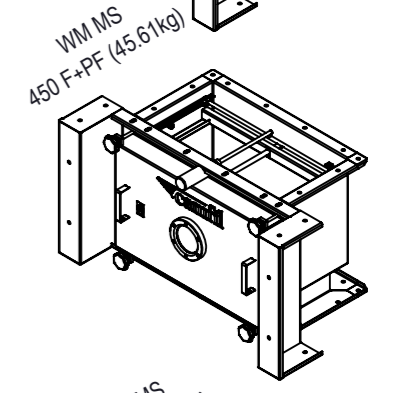
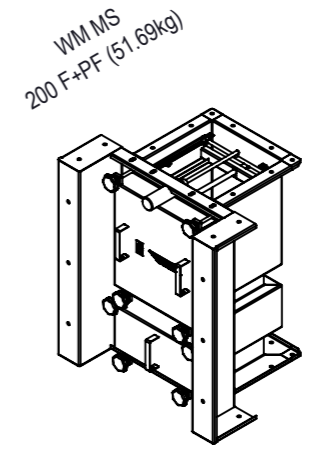
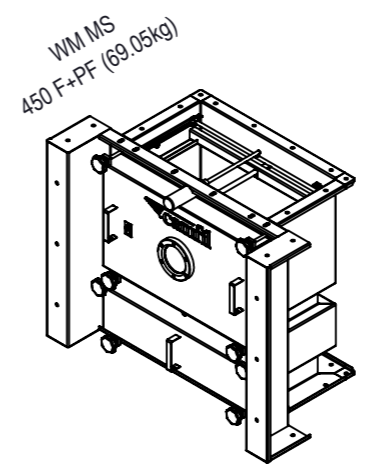
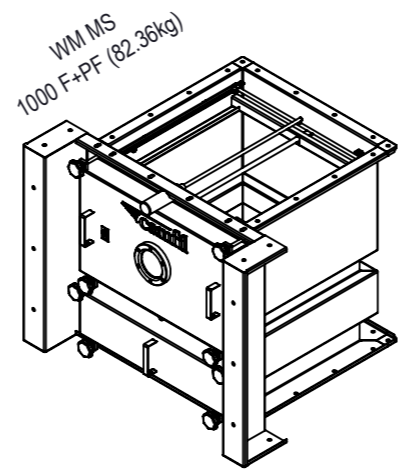
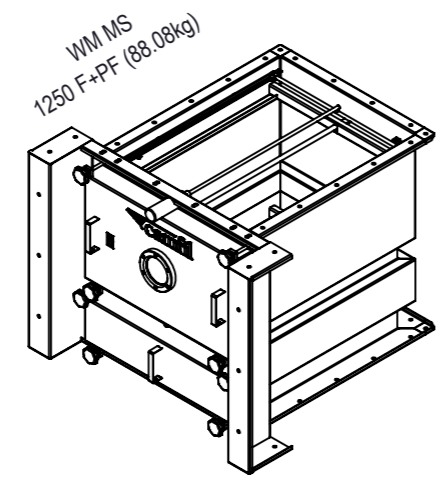
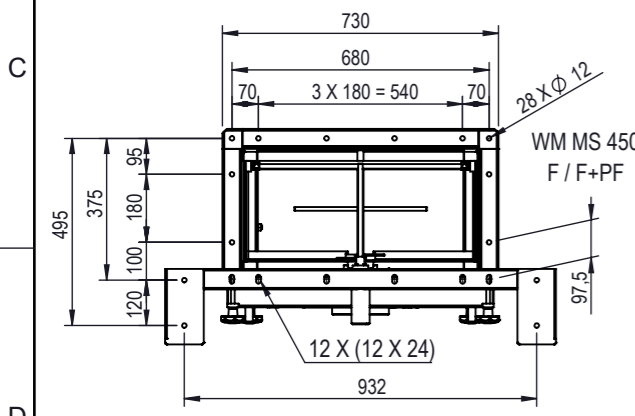
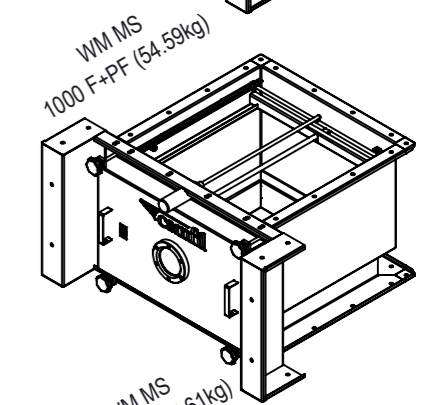
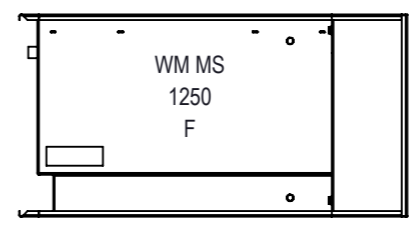
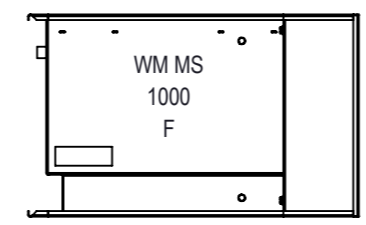
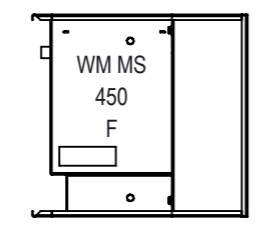
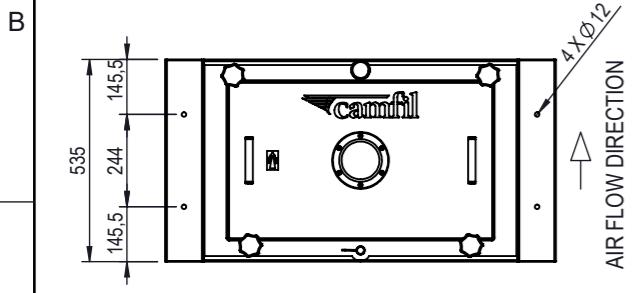
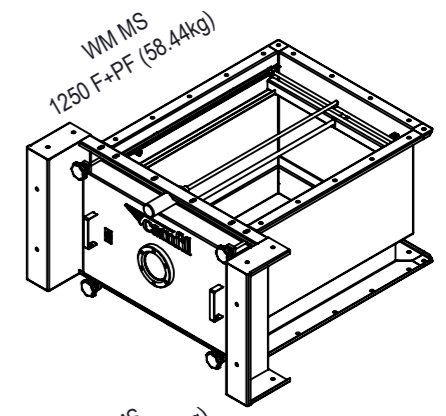
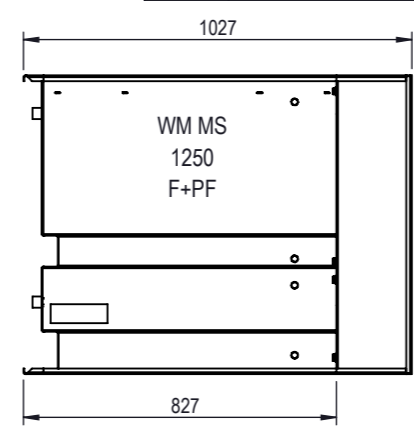
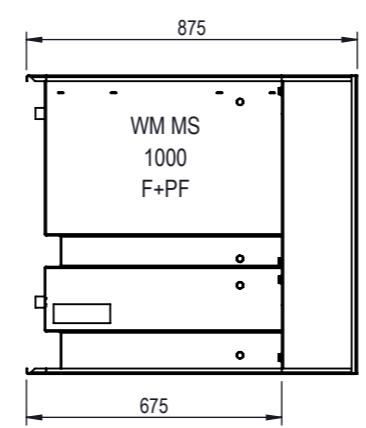
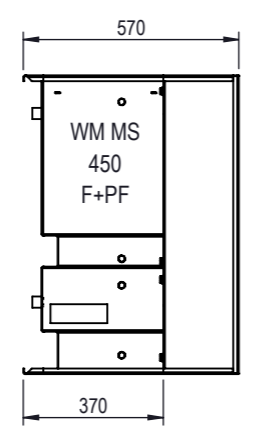
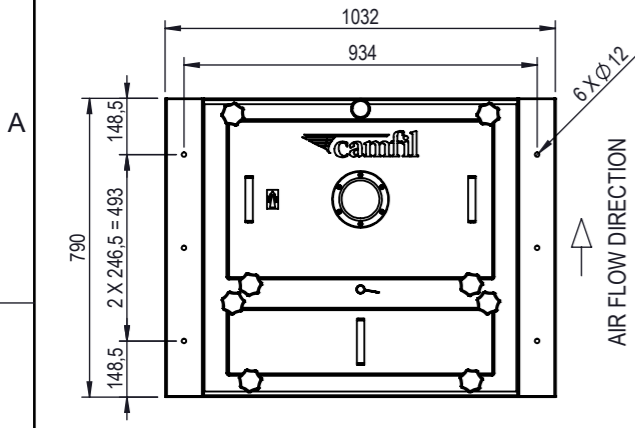

|                   |  | CAMSAFE 2 INV WM +MS          |                               |                               |                               |                               |                               |                               |                               |                               |                               |                               |  |                               |                               |                               |  |                               |                               |                               |  |                               |                               |                               |                               |                               |                               |           |  |
|-------------------|--|-------------------------------|-------------------------------|-------------------------------|-------------------------------|-------------------------------|-------------------------------|-------------------------------|-------------------------------|-------------------------------|-------------------------------|-------------------------------|--|-------------------------------|-------------------------------|-------------------------------|--|-------------------------------|-------------------------------|-------------------------------|--|-------------------------------|-------------------------------|-------------------------------|-------------------------------|-------------------------------|-------------------------------|-----------|--|
| Version           | Size                                       | 200/3P3 1F+PF                 |                               |                               |                               | 450/3P6 1F                    |                               |                               |                               | 450/3P6 1F+PF                 |                               |                               |  | 1000/6P6 1F                   |                               |                               |  | 1000/6P6 1F+PF                |                               |                               |  | 1250/7P6 1F                   |                               |                               |                               | 1250/7P6 1F+PF                |                               |           |  |
| Drawing           | 5849-1124-004                              | 5849-1124-004                 |                               |                               |                               | 5849-1154-004                 |                               |                               |                               | 5849-3154-004                 |                               |                               |  | 5849-1104-004                 |                               |                               |  | 5849-3104-004                 |                               |                               |  | 5869-1104-004                 |                               |                               |                               | 5869-3104-004                 |                               |           |  |
| Material / Finish | Painted *<br>316L *<br>304L *              | Painted *<br>316L *<br>304L * | Painted *<br>316L *<br>304L * | Painted *<br>316L *<br>304L * | Painted *<br>316L *<br>304L * | Painted *<br>316L *<br>304L * | Painted *<br>316L *<br>304L * | Painted *<br>316L *<br>304L * | Painted *<br>316L *<br>304L * | Painted *<br>316L *<br>304L * | Painted *<br>316L *<br>304L * | Painted *<br>316L *<br>304L * | Painted *<br>316L *<br>304L *                          | Painted *<br>316L *<br>304L * | Painted *<br>316L *<br>304L * | Painted *<br>316L *<br>304L * | Painted *<br>316L *<br>304L *                    | Painted *<br>316L *<br>304L * | Painted *<br>316L *<br>304L * | Painted *<br>316L *<br>304L * | Painted *<br>316L *<br>304L *                    | Painted *<br>316L *<br>304L * | Painted *<br>316L *<br>304L * | Painted *<br>316L *<br>304L * | Painted *<br>316L *<br>304L * | Painted *<br>316L *<br>304L * | Painted *<br>316L *<br>304L * |           |  |
| Item No.          | 1076786<br>1076789<br>1076788              | 1076802<br>1076805<br>1076804 | 1076790<br>1076793<br>1076792 | 1076806<br>1076809<br>1076808 | 1076794<br>1076797<br>1076796 | 1076810<br>1076813<br>1076812 | 1076798<br>1076801<br>1076800 | 1076814<br>1076817<br>1076816 |                               |                               |                               |                               |  |                               |                               |                               |  |                               |                               |                               |  |                               |                               |                               |                               |                               |                               |           |  |
|                   |  | CAMSAFE 2 INV WM +MS +W       |                               |                               |                               |                               |                               |                               |                               |                               |                               |                               |  |                               |                               |                               |  |                               |                               |                               |  |                               |                               |                               |                               |                               |                               |           |  |
| Version           | 200/3P3 1F                                 | 200/3P3 1F+PF                 |                               |                               |                               | 450/3P6 1F                    |                               |                               |                               | 450/3P6 1F+PF                 |                               |                               |  | 1000/6P6 1F                   |                               |                               |  | 1000/6P6 1F+PF                |                               |                               |  | 1250/7P6 1F                   |                               |                               |                               | 1250/7P6 1F+PF                |                               |           |  |
| Drawing           | NOT AVAILABLE                              | NOT AVAILABLE                 |                               |                               |                               | 5859-1154-004                 |                               |                               |                               | 5859-3154-004                 |                               |                               |  | 5859-1104-004                 |                               |                               |  | 5859-3104-004                 |                               |                               |  | 5839-1104-004                 |                               |                               |                               | 5839-3104-004                 |                               |           |  |
| Material / Finish | Painted *                                  | Painted *                     | Painted *                     | Painted *                     | Painted *                     | Painted *                     | Painted *                     | Painted *                     | Painted *                     | Painted *                     | Painted *                     | Painted *                     | Painted *  | Painted *                     | Painted *                     | Painted *                     | Painted *  | Painted *                     | Painted *                     | Painted *                     | Painted *  | Painted *                     | Painted *                     | Painted *                     | Painted *                     | Painted *                     | Painted *                     | Painted * |  |
| Item No.          |  |                               |                               |                               |                               |                               |                               |                               |                               |                               |                               |                               |  |                               |                               |                               |  |                               |                               |                               |  |                               |                               |                               |                               |                               |                               |           |  |
| Material          | SHEETMETAL - EN10025-2 - S235JRG2 (1.0038) |                               |                               |                               |                               |                               |                               |                               |                               |                               |                               |                               | SHEETMETAL 316L - EN10088-2 - X2CrNiMo17-12-2 (1.4404) |                               |                               |                               | SHEETMETAL 304L - EN10088 - X2CrNi18-09 (1.4307) |                               |                               |                               | SHEETMETAL 304L - EN10088 - X2CrNi18-09 (1.4307) |                               |                               |                               |                               |                               |                               |           |  |
| Finish            | Painted RAL 9010 SPEC025                   |                               |                               |                               |                               |                               |                               |                               |                               |                               |                               |                               | Pickled & Glass Blasted SPEC026                        |                               |                               |                               | Pickled & Glass Blasted SPEC026                  |                               |                               |                               | Pickled & Glass Blasted SPEC026                  |                               |                               |                               |                               |                               |                               |           |  |

NOTE:  
SPECIAL FILTERS REQUIRED

| General tolerances ISO 2768 - vL unless otherwise specified |           |
|---|-----------|
| DIMENSION   | TOLERANCE |
| < 30  | ± 1       |
| > 30 to 120   | ± 1,5     |
| > 120 to 400  | ± 2,5     |
| > 400 to 1000   | ± 4       |
| > 1000 to 4000  | ± 6       |
| > 4000  | ± 8       |
| Break sharp angles 0,5 to 2                                 |           |



| DESCRIPTION                                    |               |             |       |
|--|---------------|-------------|-------|
| CamSafe CS2 WM MS F / F+PF Inv. flow STD Scope |               |             |       |
| PROJECT  | LAST REVISION | WEIGHT      |       |
| -  | 23.08.2021    | see drawing |       |
| DRAWING REF.                                   | SHEET         | SIZE        | SCALE |
| 5899-0000-101                                  | 1/2           | A3          | 1:20  |

NB: The copyright of this drawing remains with Camfil. Contents must not be used, copied or disclosed to third parties without prior written consent. All rights reserved.

| REV. | CHANGE               | DATE       | DESIGNED | APPROVED |
|------|----------------------|------------|----------|----------|
| D    | ITEM NUMBERS CHANGED | 23.08.2021 | RIL      | VPA      |

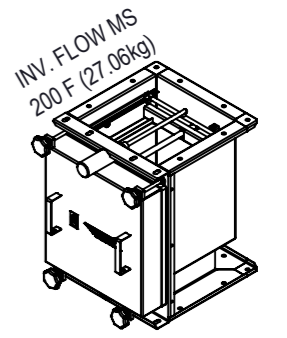
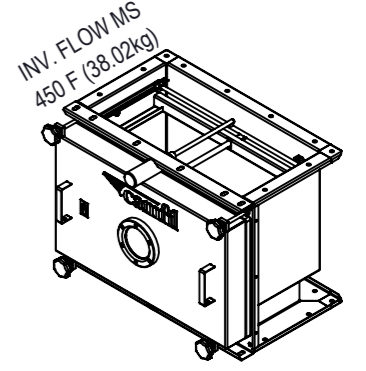
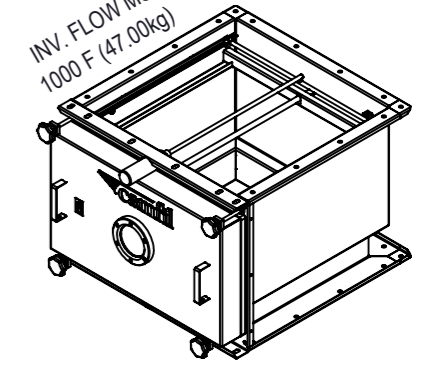
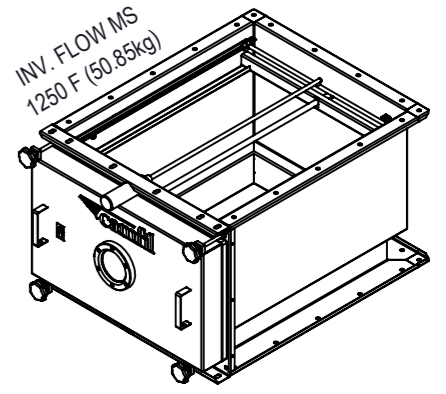
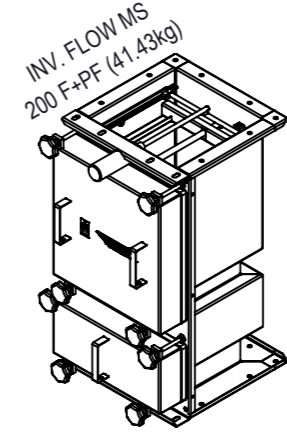
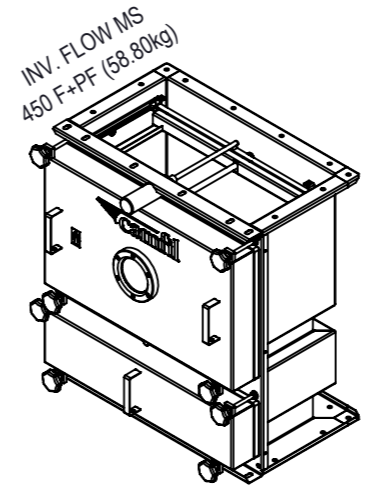
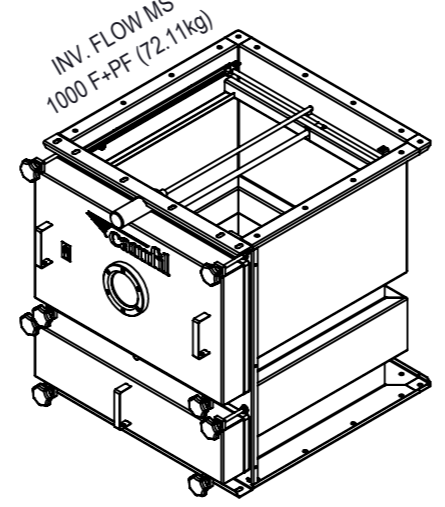
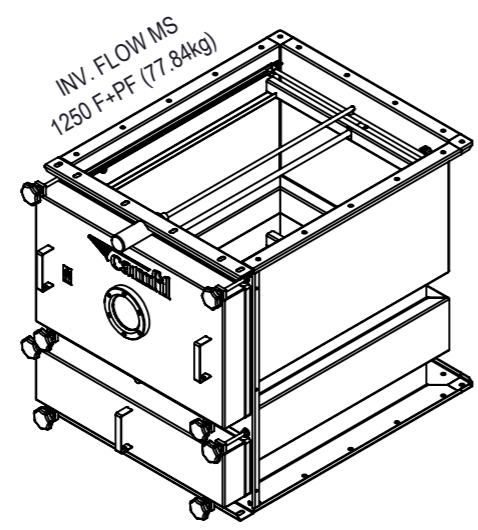
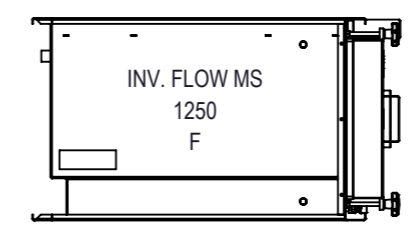
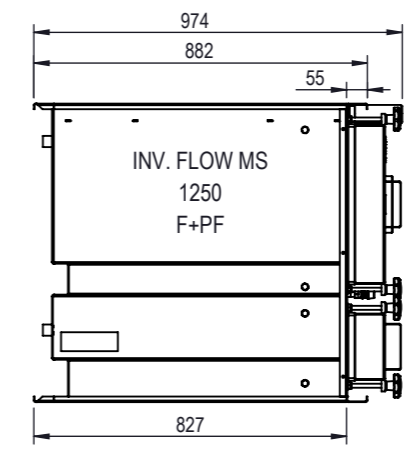
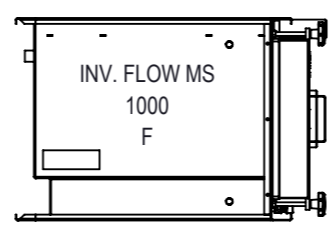
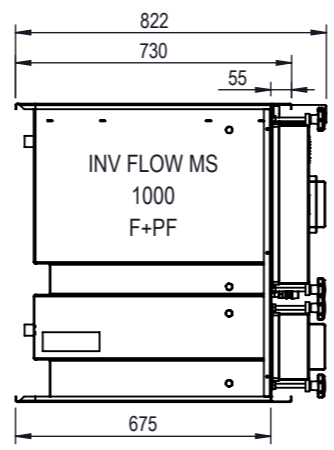
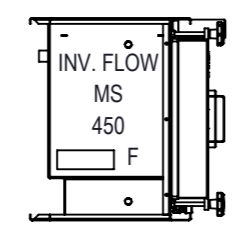
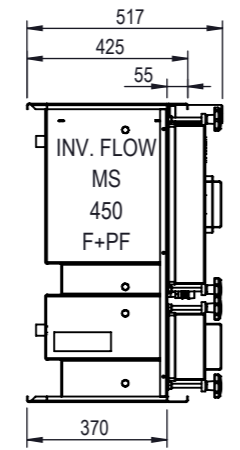
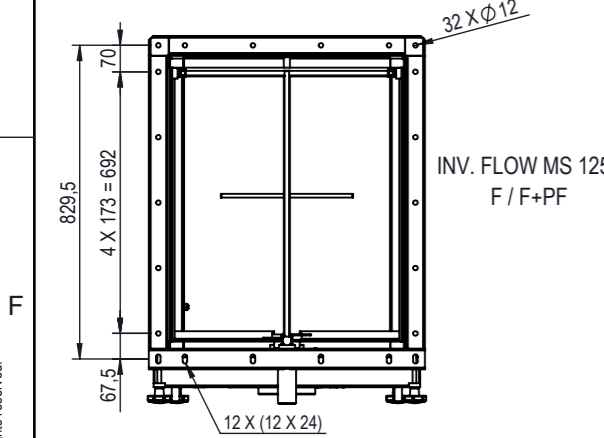
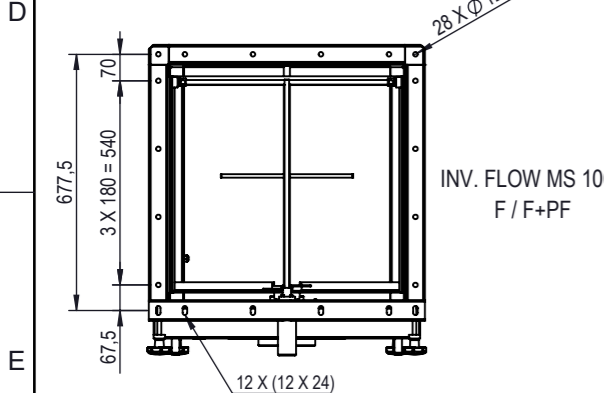
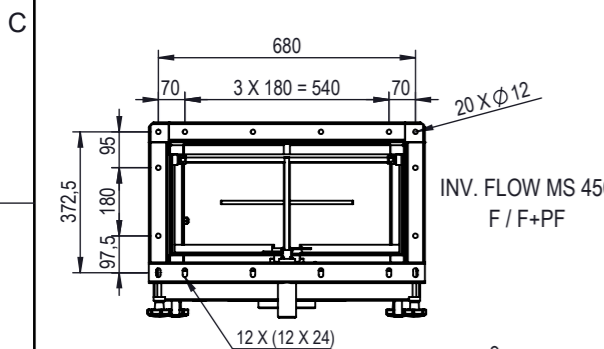
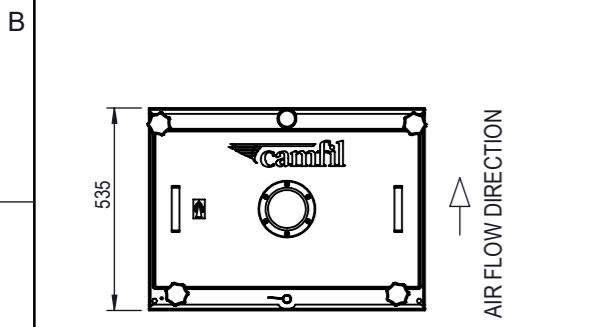
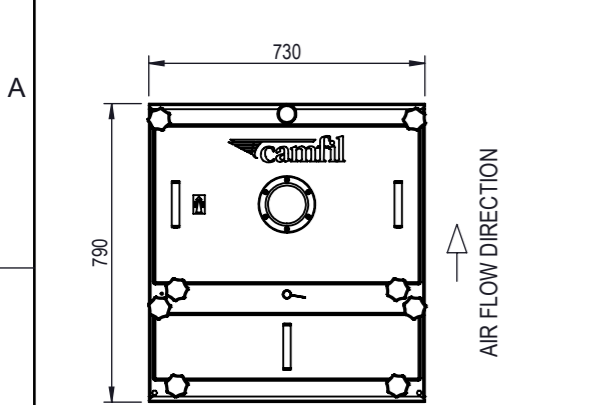

|                   |          | CAMSAFE 2 INV +MS        |         |         |               |         |         |   |         |         |               |         |         | CAMSAFE 2 INV +MS+W                                |         |         |                |         |         |               |         |         |                |         |         |         |  |  |         |  |  |         |  |  |         |  |  |         |  |  |         |  |  |         |  |  |         |  |  |         |  |  |
|-------------------|----------|--------------------------|---------|---------|---------------|---------|---------|---|---------|---------|---------------|---------|---------|--|---------|---------|----------------|---------|---------|---------------|---------|---------|----------------|---------|---------|---------|--|--|---------|--|--|---------|--|--|---------|--|--|---------|--|--|---------|--|--|---------|--|--|---------|--|--|---------|--|--|
| Version           | Size     | 200/3P3 1F               |         |         | 200/3P3 1F+PF |         |         | 450/3P6 1F  |         |         | 450/3P6 1F+PF |         |         | 1000/6P6 1F  |         |         | 1000/6P6 1F+PF |         |         | 1250/7P6 1F   |         |         | 1250/7P6 1F+PF |         |         |         |  |  |         |  |  |         |  |  |         |  |  |         |  |  |         |  |  |         |  |  |         |  |  |         |  |  |
| Drawing           | Item No. | 5849-1120-003            |         |         | 5849-3120-003 |         |         | 5849-1150-003   |         |         | 5849-3150-003 |         |         | 5849-1100-003                                      |         |         | 5849-3100-003  |         |         | 5849-1100-003 |         |         | 5849-3100-003  |         |         |         |  |  |         |  |  |         |  |  |         |  |  |         |  |  |         |  |  |         |  |  |         |  |  |         |  |  |
| Material / Finish | Item No. | Painted *                | 316L *  | 304L *  | Painted *     | 316L *  | 304L *  | Painted *   | 316L *  | 304L *  | Painted *     | 316L *  | 304L *  | Painted *  | 316L *  | 304L *  | Painted *      | 316L *  | 304L *  | Painted *     | 316L *  | 304L *  | Painted *      | 316L *  | 304L *  |         |  |  |         |  |  |         |  |  |         |  |  |         |  |  |         |  |  |         |  |  |         |  |  |         |  |  |
|                   |          | 1076754                  | 1076757 | 1076756 | 1076770       | 1076773 | 1076772 | 1076758   | 1076761 | 1076760 | 1076774       | 1076777 | 1076776 | 1076762  | 1076765 | 1076764 | 1076778        | 1076781 | 1076780 | 1076786       | 1076769 | 1076768 | 1076782        | 1076785 | 1076784 |         |  |  |         |  |  |         |  |  |         |  |  |         |  |  |         |  |  |         |  |  |         |  |  |         |  |  |
| Version           | Size     | 200/3P3 1F               |         |         | 200/3P3 1F+PF |         |         | 450/3P6 1F  |         |         | 450/3P6 1F+PF |         |         | 1000/6P6 1F  |         |         | 1000/6P6 1F+PF |         |         | 1250/7P6 1F   |         |         | 1250/7P6 1F+PF |         |         |         |  |  |         |  |  |         |  |  |         |  |  |         |  |  |         |  |  |         |  |  |         |  |  |         |  |  |
| Drawing           | Item No. | 5849-1120-003            |         |         | 5849-3120-003 |         |         | 5849-1150-003   |         |         | 5849-3150-003 |         |         | 5849-1100-003                                      |         |         | 5849-3100-003  |         |         | 5849-1100-003 |         |         | 5849-3100-003  |         |         |         |  |  |         |  |  |         |  |  |         |  |  |         |  |  |         |  |  |         |  |  |         |  |  |         |  |  |
| Material / Finish | Item No. | NOT AVAILABLE            |         |         |               |         |         | Painted *   |         |         | 316L *        |         |         | 304L *   |         |         | Painted *      |         |         | 316L *        |         |         | 304L *         |         |         |         |  |  |         |  |  |         |  |  |         |  |  |         |  |  |         |  |  |         |  |  |         |  |  |         |  |  |
|                   |          |                          |         |         |               |         |         | 1076461   |         |         | 1076464       |         |         | 1076596  |         |         | 1076599        |         |         | 1076465       |         |         | 1076467        |         |         | 1076600 |  |  | 1076603 |  |  | 1076602 |  |  | 1076469 |  |  | 1076472 |  |  | 1076471 |  |  | 1076604 |  |  | 1076607 |  |  | 1076606 |  |  |
| Material          | Finish   | Painted *                |         |         |               |         |         | SHEETMETAL 316L - EN10088-2 - X2CrNiMo17-12-2+2B (1.4404) |         |         |               |         |         | SHEETMETAL 304L - EN10088-2 - X2CrNi18-09 (1.4307) |         |         |                |         |         |               |         |         |                |         |         |         |  |  |         |  |  |         |  |  |         |  |  |         |  |  |         |  |  |         |  |  |         |  |  |         |  |  |
|                   |          | Painted RAL 9010 SPEC025 |         |         |               |         |         | Pickled & Glass Blasted SPEC026                           |         |         |               |         |         | Pickled & Glass Blasted SPEC026                    |         |         |                |         |         |               |         |         |                |         |         |         |  |  |         |  |  |         |  |  |         |  |  |         |  |  |         |  |  |         |  |  |         |  |  |         |  |  |

| General tolerances ISO 2768 - vL unless otherwise specified |           |
|---|-----------|
| DIMENSION   | TOLERANCE |
| < 30  | ± 1       |
| > 30 to 120   | ± 1,5     |
| > 120 to 400  | ± 2,5     |
| > 400 to 1000   | ± 4       |
| > 1000 to 4000  | ± 6       |
| > 4000  | ± 8       |
| Break sharp angles 0,5 to 2                                 |           |



|  |               |             |       |
|--|---------------|-------------|-------|
| DESCRIPTION                                |               |             |       |
| CamSafe CS2 MS F/ F+PF Inv. flow STD Scope |               |             |       |
| PROJECT                                    | LAST REVISION | WEIGHT      |       |
| -  | 23.08.2021    | see drawing |       |
| DRAWING REF.                               | SHEET         | SIZE        | SCALE |
| 5899-0000-101                              | 2/2           | A3          | 1:20  |

NOTE:  
SPECIAL FILTERS REQUIRED

NB: The copyright of this drawing remains with Camfil. Contents must not be used, copied or disclosed to third parties without prior written consent. All rights reserved.